

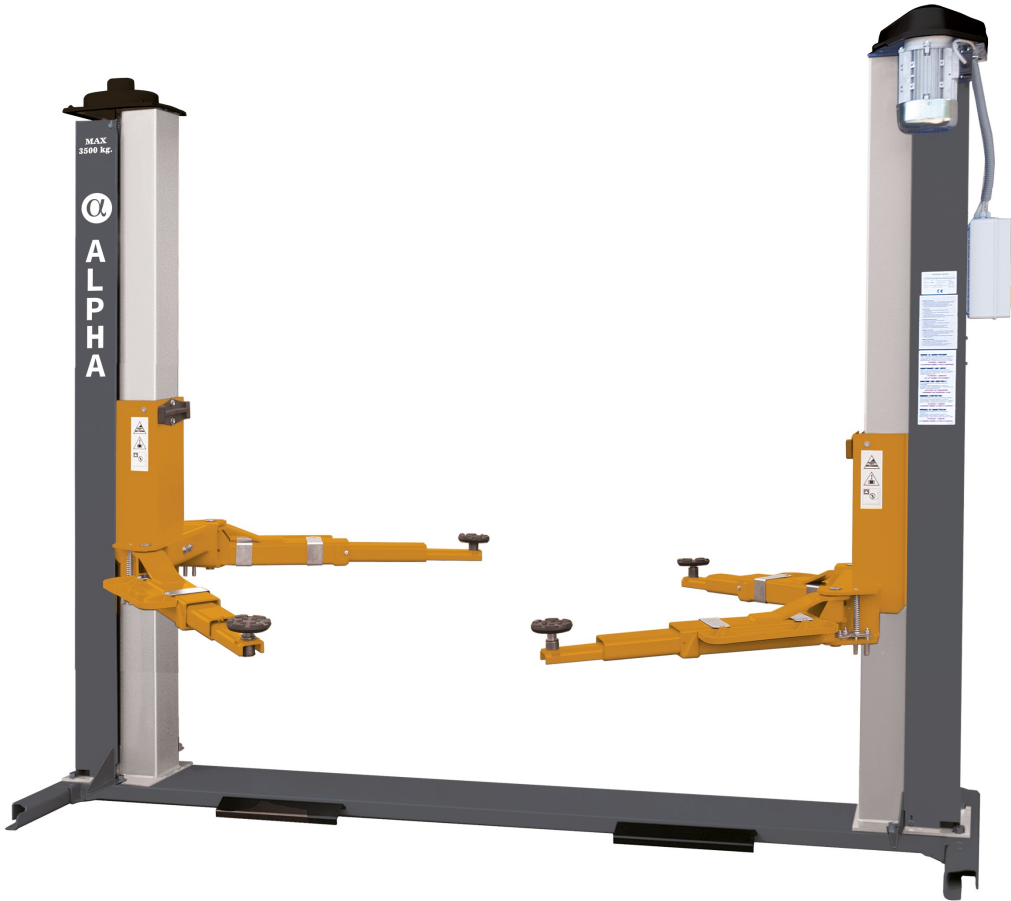

3.5t



D-5035M/B D-5035M/BL

- Electro-mechanical lift with full base frame, ideal for less than optimal floors and low ceilings;
- 3.5t capacity;
- Self-lubricating load and safety nuts;
- Chain transmission with slack safety switch;
- Rolled high resistance steel spindles;
- 3-stage symmetric arms, ideal for load reversing and lifting cars and small vans;
- Dead-man low voltage controls;
- Available in standard and wider version (with longer arms);
- Manufactured to a high standard in the EU.

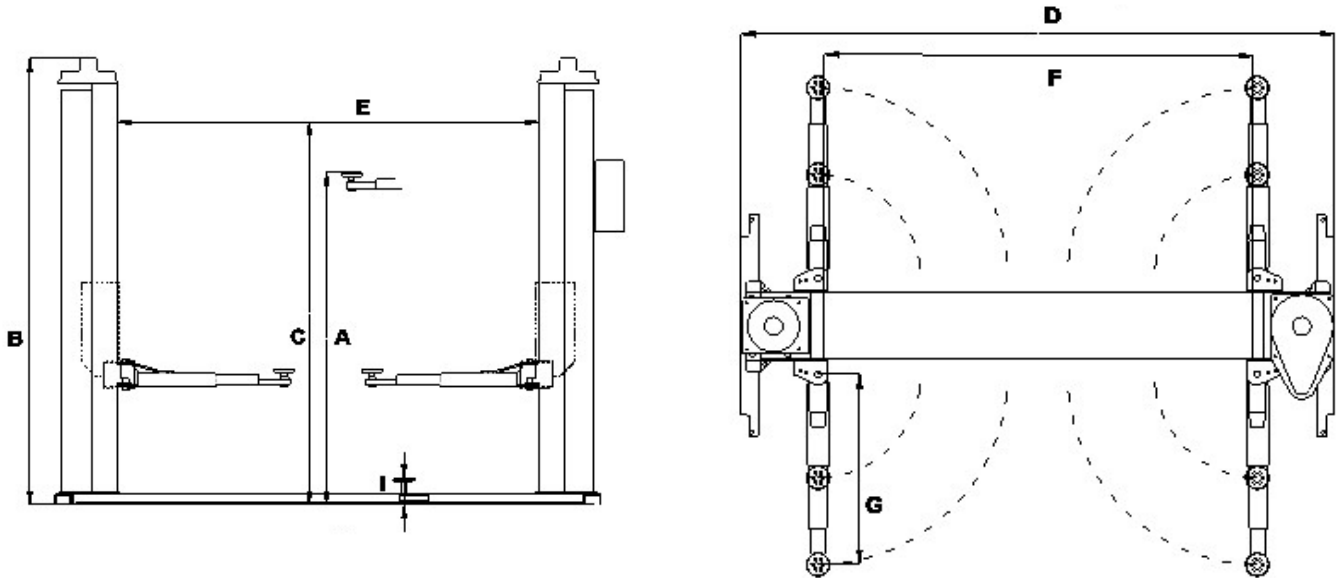

Technical Specifications

Model	D-5035M/B D5035M/BL
Capacity	3.5t
Lowering/Lifting Time	60"/60"
Motor	3kW 380-415V 50-60Hz

Measurements (mm)		D-5035M/B	D-5035M/BL
A	Max. lifting height	1950	1950
B	Overall column height	2620	2620
C	Cut off level	2445	2445
D	Overall width	3210	3450
E	Distance between columns	2480	2650
F	Drive through clearance	2440	2610
G	Min./max. arm length	560/1030	630/1130
I	Min./max. pad height	85/155	85/155